

PRODUCTS AND SERVICES

Microanalytics™ offers the most sophisticated GC-Olfactometry systems on the market today; the AromaTrax® system. Its design features represent the culmination of years of refinement and are based on extensive experience in the food, beverage, chemical and packaging industries. The unique combination of multidimensional gas chromatography, multiple detectors, a state-of-the-art olfactory detector, and a practical aroma reporting system is all integrated into a powerful olfactory analysis instrument. The instrument is completely controlled by the latest MultiTrax and AromaTrax® software and comes equipped with a touch-screen monitor interface for enhanced aroma character tracking.

The instrument delivers very high sensitivity and selectivity for finding and identifying even trace level aroma compounds in complex samples or tracking down troublesome off-odors.

Using a widely varied combination of sample collection and inlet technologies, the AromaTrax® system is able to locate, quantitate and identify aroma and off-odor compounds quickly, and with minimal sample preparation.

Microanalytics™ is a **Channel Partner** with Agilent Technologies and uses the Agilent 6890 GC as the basic platform for the AromaTrax® instrument systems.

Multidimensional AromaTrax GC/Olfactory/MS

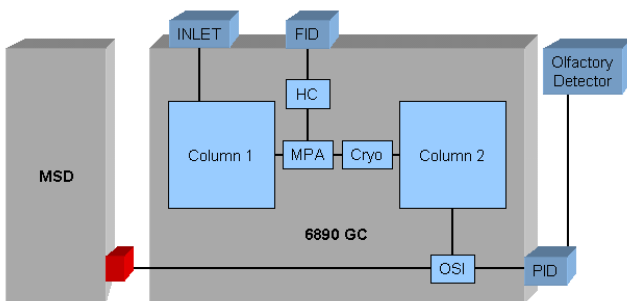

Discuss your application with us:

Microanalytics

2011 A Lamar Drive
Round Rock, Texas 78664
Phone: (512) 218-9873
FAX: (512) 218-9875
www.mdgc.com

For Information: info@mdgc.com

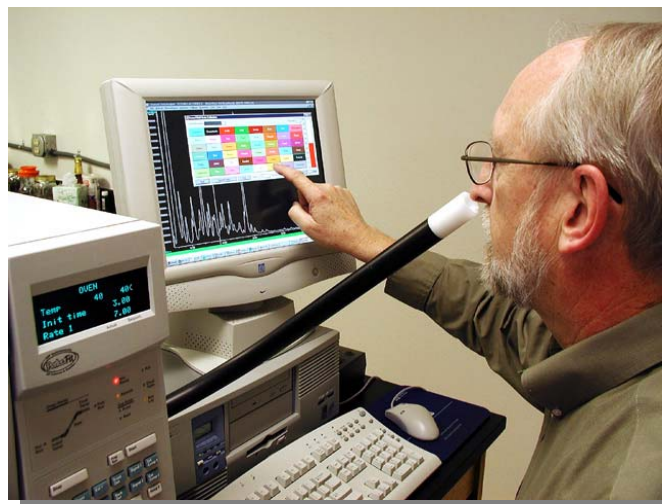

Contract Analytical Services

- Flavor / odor profiling with MS identification.
- Off-odor identification.
- Aging studies related to flavor / odor.
- Packaging related flavor problems.
- Aroma Extract Dilution Analysis.
- Chemical product odor analysis.
- Product contamination and adulteration.
- Special projects; contact us for details.

Instruments

- Single-oven multidimensional AromaTrax® GC/Olfactory/MS system.
- Dual-oven multidimensional AromaTrax® GC/Olfactory/MS system.
- Single dimensional AromaTrax® GC/Olfactory/MS system.
- Dual-oven multidimensional chiral system.
- Complete GC/Olfactory system with MS-Nose (used to develop multivariate QA analysis methods).
- Stand-alone sniff-port with all AromaTrax® software and practical report writing features.
- Custom GC/Olfactory systems integration with FTIR, AED, MSD, auto samplers, etc.
- Specialized instruments for analysis of H₂S, mercaptans and other critical odorants.

 **Microanalytics**™
A **MOCON**® Company

2011A Lamar Drive - Round Rock, TX 78664
Gas Chromatography Systems and Services